

## GEMS Relays and Barriers Render Any Non-Voltage Producing Sensor or Switch Intrinsically Safe

- ▶ Provide method of eliminating explosive conditions
- ▶ Rapid, arc-free response provides positive, non-mechanical operation
- ▶ Solid-state reliability assures consistent performance
- ▶ Low-power switching; a few milliamps of current controls high-power loads
- ▶ Completely encapsulated construction  
Units are impervious to dust, moisture or foreign material  
They are tamper-proof and shock- and vibration-resistant
- ▶ Modular housings for easier installation
- ▶ Exceptionally long, trouble-free service life

### Intrinsic Safety and its Advantages.

#### Instrument Society of American Specification ISA-RP12.2 Defining Intrinsically Safe Equipment:

“Intrinsically safe equipment and wiring is equipment and wiring which is incapable of releasing sufficient electrical or thermal energy under normal or abnormal conditions to cause ignition of a specific hazardous atmospheric mixture in its most ignited concentration. Intrinsically safe terminations and wiring may be brought into any hazardous location of any Group classification for which it is accepted without requiring explosion-proof housing or other means of protection.”

To be certified “intrinsically safe,” a device or circuit must be so designed that no two simultaneous failures can cause an explosion. Intrinsically safe systems are more dependable. The I.S. circuit must function reliably per specifications, with no explosions, during and after cycling through a number of operations.

The units can also be installed more conveniently. Since no explosion is possible, no explosion-proof conduit or enclosures of any kind are needed in the hazardous area. Maintenance can be performed immediately as needed. And, intrinsically safe systems are more economical. Costly enclosures with their mounting requirements are unnecessary. No purging is required, thereby eliminating blowers, pressure switches, timers and relays.

**SAFE-PAK® RELAYS:** These intrinsically safe units amplify sensor load-handling capabilities in a wide diversity of AC and DC control switching applications.

**Zener Barriers:** These passive, energy-limiting devices, provide intrinsically safe DC outputs for a variety of sensors such as level and flow switches...level indicating transducers and transmitters...and many others. The maximum energy possible at the switch terminals of the SAFE-PAK and Zener Barriers is far below the explosive point of the most volatile surrounding gas conditions. The type of non-voltage-producing switch or sensor best suited for the application can be utilized, since the entire switching circuit is rendered intrinsically safe by the SAFE-PAK or Zener Barrier. As the switching circuit is low voltage, there is no shock hazard to operating or maintenance personnel.



## Typical Applications

### Switches Located in Hazardous Areas

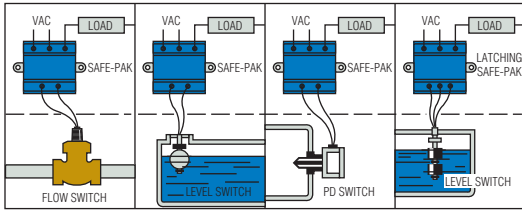

### Important points to remember when selecting Zener Barriers and Safe Pak® :

- The maximum input voltage rating of the barrier must be higher than your power supply. (i.e., a 24 VDC supply would require a 30 V barrier.)
- Make sure the barrier is rated for your hazardous area class, division, and group.

## Intrinsic Safety Approvals – Safe-Pak® Relays and Zener Barriers

| Model                       | Part Number | Approvals |    |     | Hazardous Locations |          |       |   |   |   |   | Page Number |               |             |
|-----------------------------|-------------|-----------|----|-----|---------------------|----------|-------|---|---|---|---|-------------|---------------|-------------|
|                             |             | UL        | FM | CSA | Class               | Division | Group |   |   |   |   |             |               |             |
|                             |             |           |    |     |                     |          | A     | B | C | D | E |             | F             | G           |
| SAFE-PAK®                   | 22445       | •         | •  | •   | I, II               | 1, 2     | •     | • | • | • | • | •           | •             | L-4 and L-5 |
|                             | 25872       | •         | •  | •   |                     |          | •     | • | • | • | • | •           | •             |             |
|                             | 25873       | •         | •  | •   |                     |          | •     | • | • | • | • | •           | •             |             |
|                             | 64101       | •         | •  | •   |                     |          | •     | • | • | • | • | •           | •             |             |
|                             | 144600      | •         | •  | •   |                     |          | •     | • | • | • | • | •           | •             |             |
| Programmable SAFE-PAK®      | 54820       | •         | •  | •   | I, II               | 1, 2     | •     | • | • | • | • | •           | L-6 and L-7   |             |
|                             | 54825       | •         | •  | •   |                     |          | •     | • | • | • | • | •           |               |             |
|                             | 54845       | •         | •  | •   |                     |          | •     | • | • | • | • | •           |               |             |
|                             | 54801       | •         | •  | •   | I, II               | 1, 2     |       |   |   | • |   |             | L-10 and L-11 |             |
|                             | 54803       | •         | •  | •   |                     |          | •     | • |   |   |   |             |               |             |
|                             | 54805       | •         | •  | •   |                     |          | •     | • |   |   |   |             |               |             |
|                             | 54806       | •         | •  | •   |                     |          | •     | • |   |   | • |             |               |             |
| Zener Barriers <sup>2</sup> | 111950      | •         | •  | •   | I, II               | 1, 2     | •     | • | • | • | • | •           | L-8 and L-9   |             |
|                             | 111952      | •         | •  | •   |                     |          | •     | • | • | • | • | •           |               | •           |
|                             | 111954      | •         | •  | •   |                     |          | •     | • | • | • | • | •           |               | •           |
|                             | 111956      | •         | •  | •   |                     |          | •     | • | • | • | • | •           |               | •           |
|                             | 113000      | •         | •  | •   |                     |          | •     | • | • | • | • | •           |               | •           |
|                             | 114072      | •         | •  | •   |                     |          | •     | • | • | • | • | •           |               | •           |
|                             | 114074      | •         | •  | •   |                     |          | •     | • | • | • | • | •           |               | •           |
|                             | 114166      | •         | •  | •   |                     |          | •     | • | • | • | • | •           |               | •           |
| 114175                      | •           | •         | •  | •   | •                   | •        | •     | • | • | • |   |             |               |             |

#### Notes:

1. Certified intrinsically safe under MSHA certification No. 1662 for use on permissible equipment. For Group D use only.
2. Zener Barrier models, Part Numbers 54801, 54803, 54805, 54806; Programmable SAFE-PAK models, Part Numbers 54820, 54825, 54845 are certified by CSA for mounting inside a suitable enclosure in Division 2 or non-hazardous locations and must be connected by means of the two studs provided to grounded copper busbar or equivalent.

For information on non-intrinsically safe holding relays and switching units, see Pages L-12 and L-13.

MSHA — Bureau of Mines



UL — Underwriter's Laboratories, Inc.



FM — Factory Mutual



CSA — Canadian Standards Association

## Installation and Maintenance

SAFE-PAK and Zener Barrier units are installed in a safe area and connected to the sensor in a hazardous location...no explosion-proof or protective housings of any kind are needed. Units install singly, in any position...or can be grouped on a common, earth-grounded plate with mounting tabs to provide electrical grounding. No. 6-32 threaded electrical terminals are conveniently placed atop the unit housings. Barriers and relays may be grouped on a common, earth-grounded mounting plate. Intrinsically safe sensor wiring must be separated from non-intrinsically-safe input wiring in separate conduits or raceways to prevent by-pass during testing or servicing.

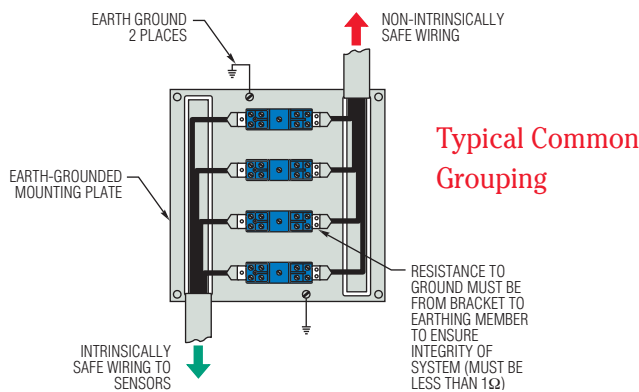

The only maintenance normally required is routine inspection approximately every two years or less to check integrity of earth-grounding and electrical connections, and to make sure the unit is clean.

GEMS SAFE-PAKS and Zener Barriers must be installed in conformance with the National Electrical Code and the INSTRUCTION, INSTALLATION AND SERVICE Bulletin supplied with all units. Periodic checks of ground bonding and cleanliness of units and terminals constitute the only maintenance required.

### Warning

Misapplication of intrinsically safe products may result in injuries or damages. The circuit diagrams presented in this catalog are typical and may not represent your application.

## Hazardous Locations as defined by the National Electrical Code Handbook. . .

The degree of hazard is normally indicated by a three-part designation: "Class-, Division, and Group-." Class I, Division 1, Group A denotes the most severely and continually hazardous condition.

**Class I Locations** — Are those in which flammable bases or vapors are or may be present in the air in quantities sufficient to produce explosive or ignitable mixtures.

**Class II Locations** — Are those which are hazardous because of the presence of combustible dust.

**Class III Locations** — Are those which are hazardous because of the presence of easily ignitable fibers or flyings, but in which such fibers or flyings are not likely to be in suspension in air quantities sufficient to produce ignitable mixtures.

**Division 1** — Locations in which hazardous concentrations in the air exist continuously, intermittently, or periodically under normal operating conditions.

**Division 2** — Locations in which hazardous concentrations are handled, processed, or used, but are normally confined within closed containers or closed systems from which they can escape only in case of accidental rupture or breakdown.

**Group A** — Atmospheres containing acetylene.

**Group B** — Atmospheres containing hydrogen, or gases or vapors of equivalent hazard, such as manufactured gas.

**Group C** — Atmospheres containing ethyl-ether vapors, ethylene or cyclopropane.

**Group D** — Atmospheres containing gasoline, hexane, naphtha, benzene, butane, propane, alcohol, acetone, benzol, lacquer solvent vapors or natural gas.

**Group E** — Atmospheres containing metal dust, including aluminum, magnesium, and their commercial alloys and other metals of similarly hazardous characteristics.

**Group F** — Atmospheres containing carbon black, coal or coke dust.

**Group G** — Atmospheres containing flour, starch, or grain dusts.

# Intrinsically SAFE-PAK® Relays Amplify Sensor Load-Handling Capabilities

Costly explosion-proof enclosures with their mounting requirements are unnecessary. No purging is required.

**SAFE-PAK:** Less than 100 microamps at 9 VDC actuates the unit to control loads to 5A at 120 VAC. Resistive (up to 100,000Ω) or short-circuiting sensors operate the unit. 120 VAC and 240 VAC model.

**Low Sensitivity SAFE-PAK:** Sensor closures up to 1000Ω resistance control resistive loads to 5A at 120 VAC. 120 VAC, N.O. model.

See table on Page L-2 for specific approval information.

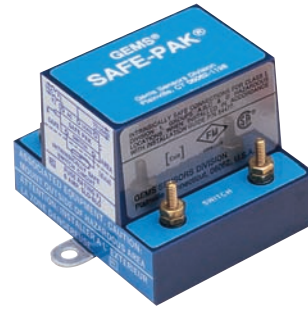

P/N  
22445  
25872  
25873  
64101



P/N  
144600



## Dimensions

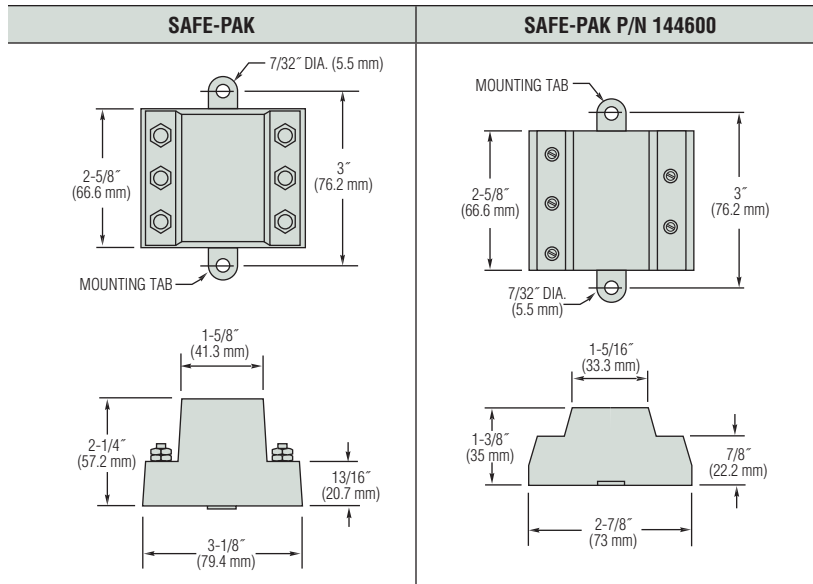

## How To Order

Select Part Number based on Relay Style, Operating Voltage and Switch Operation required.

| Relay Style               | Operating & Load Voltage Range | Load Current Maximum                                     | Turn-On Sensitivity (Typical) <sup>1</sup> | Turn-Off Sensitivity (Typical) <sup>1</sup> | Voltage Loss | Operating Temperature Range        | Output Leakage Current Maximum | Switching Operation | Part Number          |
|---------------------------|--------------------------------|----------------------------------------------------------|--------------------------------------------|---------------------------------------------|--------------|------------------------------------|--------------------------------|---------------------|----------------------|
| SAFE-PAK®                 | 95 to 135 VAC                  | 5A                                                       | 400 K                                      | 1 M                                         | 2 VAC        | 0°F to +120°F (-17.8°C to +48.9°C) | 6 mA @ 120 VAC                 | SPST N.O.           | 22445 <sup>5</sup> ⚡ |
|                           | 100 to 135 VAC                 |                                                          |                                            |                                             |              |                                    | 6 mA @ 120 VAC                 | SPST N.C.           | 25872 <sup>5</sup> ⚡ |
|                           | 200 to 250 VAC                 |                                                          |                                            |                                             |              |                                    | 12 mA @ 250 VAC                | SPST N.O.           | 25873 ⚡              |
| Low Sensitivity SAFE-PAK® | 110 to 130 VAC                 | .5A @ 20 VAC <sup>2</sup><br>.05A @ 200 VAC <sup>2</sup> | 300                                        | 1000                                        | —            | -10°F to +140°F (-23.3°C to +60°C) | 0                              | SPST N.O.           | 64101 ⚡              |
|                           | 105 to 125 VAC                 | 5A                                                       | 500                                        | 2000                                        | 2 VAC        | -40°F to +120°F (-40°C to +48.9°C) | 6 mA @ 120 VAC                 | SPST N.O.           | 144600 ⚡             |

Notes:

- Temperature Dependent.
- 50-60 Hz
- All AC voltage and current specifications are RMS values unless otherwise stated.
- Housing material is Polysulfone.
- Certified intrinsically safe under MSHA certification No. 1662 for use on permissible equipment. For Group D use only.

⚡ – Stock Items.

**Typical Wiring Diagrams**

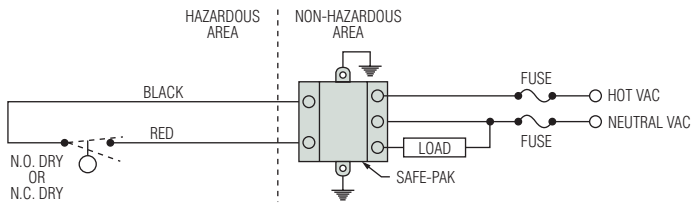

SAFE-PAK, Part Numbers 25872, 25873, 64101 or 144600 with sensor switch in hazardous location.

Transient Protection for SAFE-PAK (AC Loads) Use a properly sized metal oxide varistor (MOV) as shown below.

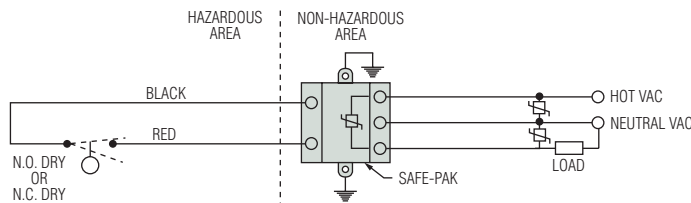

Installation and maintenance must be in accordance with the National Electrical Code and the applicable GEMS INSTRUCTION, INSTALLATION and SERVICE bulletin available at [www.gemssensors.com](http://www.gemssensors.com)

# Define Switching Mode Anytime With Programmable SAFE-PAK® Relays

Provide normally open (N.O.), normally closed (N.C.) or latching output with variable time delays

- ▶ Designed for use with switches or sensors monitoring flow, pressure, level, etc
- ▶ They render non-voltage-producing sensors intrinsically safe for operation in potentially hazardous areas
- ▶ Streamlined housing suited for group-mounting on a common earth-grounded plate for multiple installation
- ▶ UL recognized, FM, CSA and evaluated by MSHA

Operations such as normally open, normally closed or latching are programmed into these versatile SAFE-PAK units by the user during installation. Selection is made by simply connecting sensor wiring (and jumper wire when required) to the proper terminals on the unit as diagrammed on opposite page. All units are programmable, except where otherwise indicated.

See table on Page L-2 for specific approval information.

## Options

SAFE-PAK Relays can be supplied with any of the following options on special order. Please consult factory.

- With optically isolated operation
- With zero-crossover load switching
- Longer time delays
- Rail-mounting clip (in addition to standard mounting tabs)

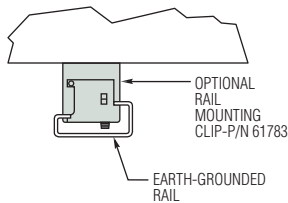

## Dimensions

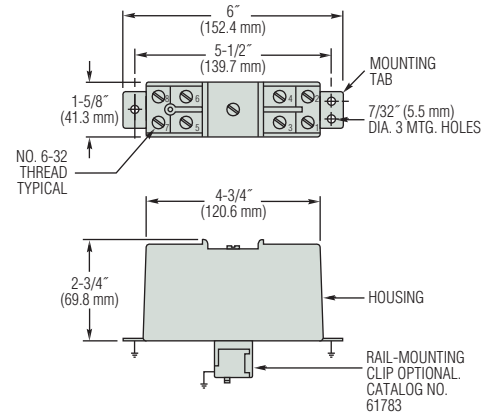

## Protective Cover

Assures intrinsic safety integrity of sensor terminals and wiring.

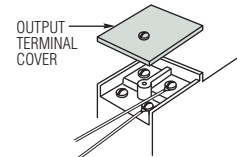

## Specifications

| Part Number | Operating Voltage <sup>4</sup> | Load Current Maximum                    | Load Voltage Range                  | Turn-On Sensitivity (Typical) <sup>1</sup> | Turn-Off Sensitivity (Typical) <sup>1</sup> | Leakage Current "Off" State, Maximum | Voltage Loss, Maximum | Transient Current <sup>3</sup> | Operating Temperature Range      |
|-------------|--------------------------------|-----------------------------------------|-------------------------------------|--------------------------------------------|---------------------------------------------|--------------------------------------|-----------------------|--------------------------------|----------------------------------|
| 54820 ⚡     | 95 to 125 VAC, 50-60 Hz        | 2A                                      | 25-250 VAC<br>50-60 Hz              | ≤400 K                                     | 1 M                                         | 3 mA                                 | 2 V                   | 20A                            | +32°F to +140°F<br>(0°C to 60°C) |
| 54825 ⚡     |                                | .05A @ 20 V<br>.05A @ 200 V<br>AC or DC | 0-250 VAC<br>50-400 Hz<br>0-200 VDC | ≤30 K                                      | 60 K                                        | —                                    | —                     | —                              |                                  |

Notes:

1. Temperature Dependent.
2. Housing material is blue Lexan®.
3. Repetitive surge currents caused by transient voltage/current pulses may eventually cause permanent damage to triac-type switches if adequate transient suppression is not utilized.
4. All AC voltage and current specifications are RMS values unless otherwise stated.

⚡ – Stock Items.



## How To Order

Specify Part Number based on output.

| Description – Hybrid Relay          | Switching Mode                              | Part Number |
|-------------------------------------|---------------------------------------------|-------------|
| Triac Output, AC Operation          | Programmable,<br>N.O., N.C.,<br>or latching | 54820 ⚡     |
| Reed Switch Output, AC/DC Operation |                                             | 54825 ⚡     |
| Optional Rail Mounting Clip         |                                             | 61783       |

⚡ – Stock Items.

## Programming the GEMS Programmable SAFE-PAK

**Normally Open Load Operation:** Switch closure to terminals 5 and 7 turns Programmable Relay “on” and energizes load. Same switch opening will turn “off” Programmable Relay and de-energize load. Terminals 6 and 8 are not used.

**Normally Closed Load Operation:** Switch closure to terminals 6 and 7 turns Programmable Relay “off” and de-energizes load. Same switch opening will turn “on” Programmable Relay and energize load. Jumper must be connected between terminals 5 and 7...terminal 8 is not used.

**Latching “A” Operation:** For refill control, momentary switch closure to terminals 5 and 7 turns Programmable Relay “on” and energizes load. Load remains “on” until the Programmable Relay turns “off” with a momentary switch closure at terminals 6 and 7. The load is then de-energized. Jumper must be connected between terminals 7 and 5 and 6.

Note: Latching function should be accomplished on sensor input side of the Programmable SAFE-PAK. No latching function is advised on the output power circuit side.

**Latching “B” Operation:** Momentary switch closure to terminals 5 and 7 turns Programmable Relay “on” and energizes load. Load remains “on” until the N.C. switch terminals 7 and 8 opens. The Programmable Relay turns “off” and load is de-energized. Terminal 6 and jumper are not used.

Note: Latching function should be accomplished on sensor input side of the Programmable SAFE-PAK. No latching function is advised on the output power circuit side.

## Typical Wiring

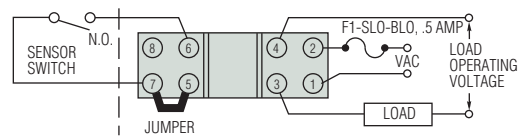
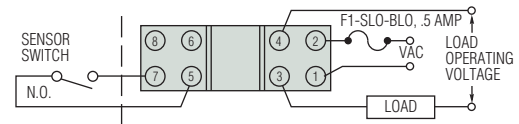

## Refill Operation Shown

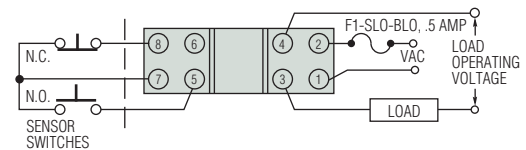
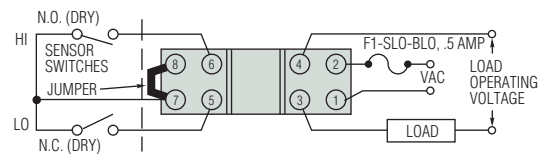

## Load Consideration

When these units are used in high-noise electrical systems, connection of a varistor (General Electrical G-MOV or equivalent diode) across terminals 3 and 4 is recommended. Consult factory for recommended varistor protection.

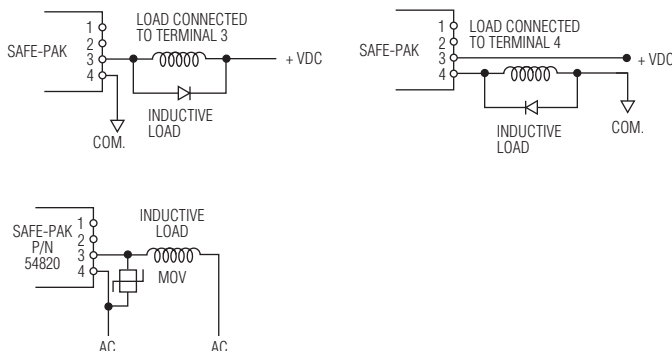

## Connecting to Programmable Controllers

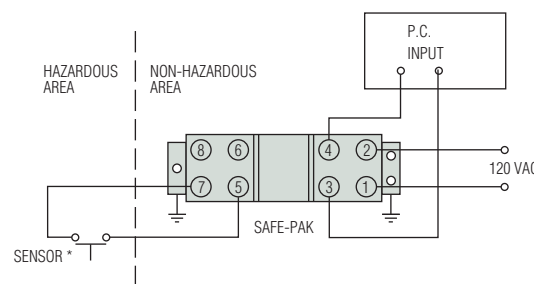

Programmable SAFE-PAK, P/N 54825, providing simple on-off functions for hazardous location, and interfacing with TTL or AC logic input of programmable controller. \*Temperature, pressure, position, flow or level.

Installation and maintenance must be in accordance with the National Electrical Code and the applicable GEMS INSTRUCTION, INSTALLATION and SERVICE Bulletin available at [www.gemssensors.com](http://www.gemssensors.com)

# 65800 Series Single Channel Zener Barriers Render Switches or Signal Conditioners Intrinsically Safe

Limits D.C. voltage and current to the hazardous area and provides a path for fault current

- ▶ Intrinsic safety with solid-state reliability
- ▶ Compact size streamlines installation
- ▶ Space-saving in multiples
- ▶ Encapsulated construction is impervious to dust and moisture

The exceptionally compact design of GEMS 65800 Series units saves space and simplifies installation; especially in multiples on a common mounting plate. They provide great economy as well since no explosion-proof enclosures are needed for sensor wiring. Encapsulated construction is impervious to dust and moisture. Single-screw mounting is standard, but units can be supplied with an optional clip for rail mounting. The single through-mounting screw also provides electrical connection to ground through the earth-grounded mounting surface.

Any non-voltage-producing sensor or switch is rendered intrinsically safe for hazardous locations when properly connected to the output of these Zener Barriers.

See table on Page L-2 for specific approval information.

## Typical Wiring Diagram

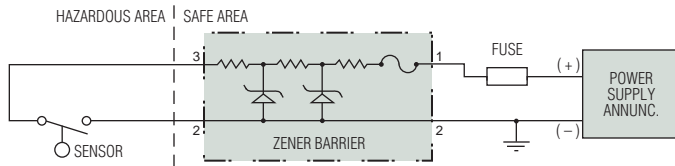

## Positive single-channel Zener Barrier with negative ground.

For most non-voltage-producing devices located in a hazardous area, a single Zener Barrier that is negative-earth-ground can be used for intrinsic safety. Instrumentation that produces an output (signal conditioners) usually requires two barriers, one for each "floating" lead. In this case, a dual channel barrier can be provided (see L-10 and L-11).

Or, for applications where the instrument signal return level cannot be reduced, a supply barrier and a low resistance return barrier can be supplied (shown below).

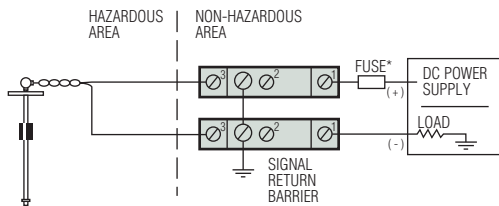

For floating leads: 65800 Series supply and return barriers for signal conditioners.

Installation and maintenance must be in accordance with the National Electrical Code and the applicable Gems INSTRUCTION, INSTALLATION and SERVICE bulletin available at [www.gemssensors.com](http://www.gemssensors.com)

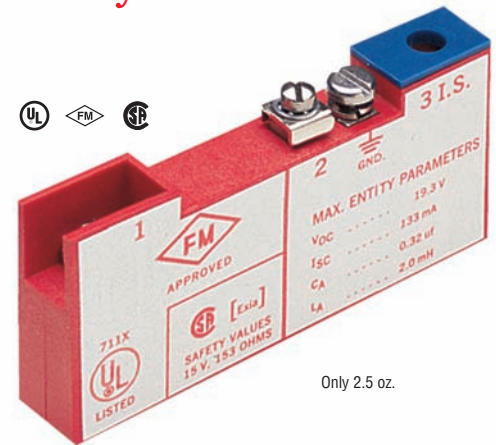

## Dimensions

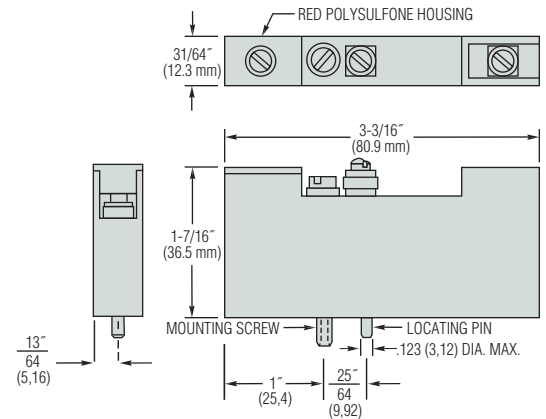

## Protective Cover

Protective cover over the output terminal (3) assures intrinsic safety of sensor wiring.

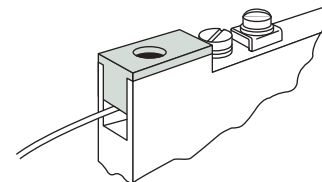

## Optional Rail Mounting

Gems Single Channel Zener Barriers can be supplied on special order with a clip for rail mounting. Clip attaches to barrier with standard mounting screw.

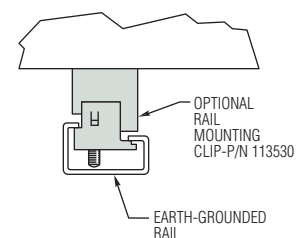



## How To Order

Specify Part Number based on Barrier Type and Input Power requirements.

| Zener Barrier Type | DC Input to Barrier, Max. |         | Signal Polarity | Series Resistance ohms | Application Group | Reactive Limits     |               | Part Number     |
|--------------------|---------------------------|---------|-----------------|------------------------|-------------------|---------------------|---------------|-----------------|
|                    | Voltage                   | Current |                 |                        |                   | Capacitance $\mu$ f | Inductance mh |                 |
| Supply             | +15                       | 250 mA  | Positive        | 183                    | A, B, C, D, E, G  | 0.32                | 2.0           | <b>111950</b> ⚡ |
|                    | +20                       | 125 mA  |                 | 303                    |                   | 0.18                | 4.1           | <b>111952</b>   |
|                    | +24                       | 62 mA   |                 | 390                    |                   | 0.12                | 3.0           | <b>111954</b> ⚡ |
|                    | +30                       | 62 mA   |                 | 750                    |                   | 0.07                | 1.8           | <b>111956</b> ⚡ |
|                    | +18                       | 125 mA  |                 | 183                    | C, D, E, G        | 0.72                | 3.6           | <b>114074</b>   |
|                    | +24                       | 62 mA   |                 | 234                    |                   | 0.33                | 3.1           | <b>114072</b>   |
|                    | +27                       | 62 mA   |                 | 276                    |                   | 0.24                | 3.3           | <b>114175</b>   |
|                    | +30                       | 250 mA  |                 | 303                    |                   | 0.20                | 3.0           | <b>113000</b> ⚡ |
| Signal Return      | +30                       | 250 mA  |                 | 33.9                   | A, B, C, D, E, G  | 0.07                | .35           | <b>114166</b> ⚡ |
| Optional Rail Clip |                           |         |                 |                        |                   |                     |               | <b>113530</b> ⚡ |

### Notes:

- All models shown are for Class I and II, Division 1 and 2. Specific Application Groups are tabulated.
- Ambient operating temperatures for all models shown is -40°F to +140°F (-40°C to +60°C).

⚡ – Stock Items.

## Typical Application Examples

Sensors or Switches may be any non-voltage-producing device. Typical are: flow and level switches, temperature switches (thermostats), pressure switches or passive resistive transducers or transmitters. Below are typical examples.

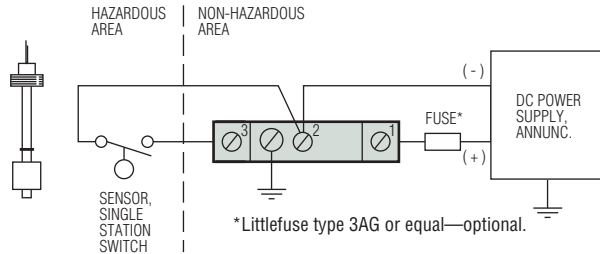

With GEMS level switch or any other non-voltage-producing device located in a hazardous area.

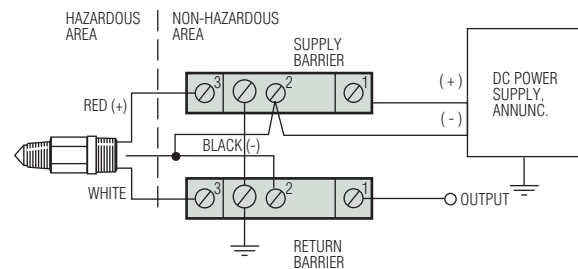

Supply and Return Zener Barriers used with GEMS EL-1100 Series electro-optical level switch.

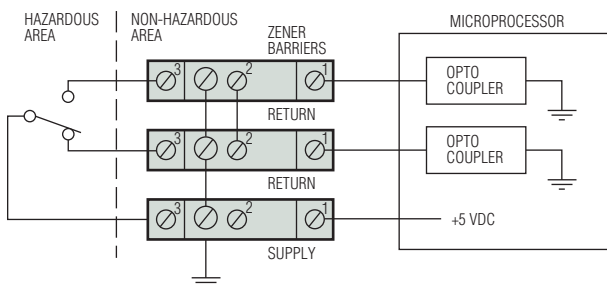

For optically coupled microprocessor. 65800 Series supply with two return barriers for SPDT switch.

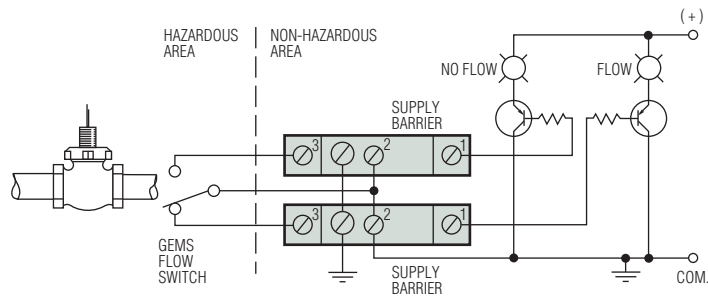

Used with GEMS flow switch located in a hazardous area for flow/no flow indication.

# 54800 Series Dual Channel Zener Barriers Provide Intrinsic Safety to Signal Producing Sensors

- ▶ Intrinsic safety with solid-state reliability
- ▶ Since no explosion-proof enclosures are needed for sensor wiring, these units further provide economical installation
- ▶ With encapsulated construction, 54800 Series Barriers are impervious to dust and moisture
- ▶ Optional clip available for rail mounting

For most non-voltage-producing devices located in a hazardous area, a single zener barrier that is negative-earth-grounded (see preceding two pages) can be used for intrinsic safety.

Instrumentation that produces an output (signal conditioners) usually requires two barriers, one for each "floating" lead. In this case, select one of the 54800 Series dual channel barriers shown here.

Any non-voltage-producing sensor or switch is rendered intrinsically safe for hazardous locations when properly connected to the output of these Zener Barriers. See table on Page L-2 for specific approval information.

### Optional Rail Mounting

Gems SAFE-PAK Relays can be supplied on special order with a clip for rail mounting. Clip is in addition to standard mounting tabs.

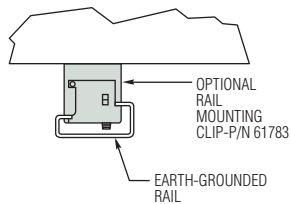

### Dimensions

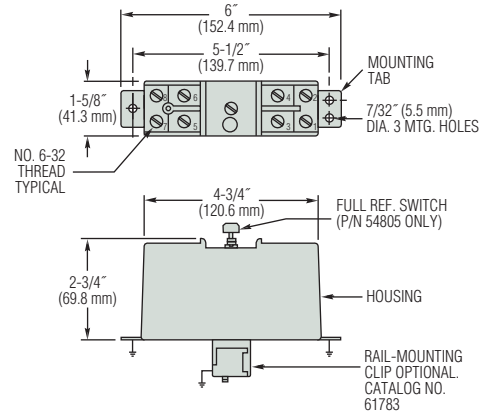

### Protective Cover

Assures intrinsic safety integrity of sensor terminals and wiring.

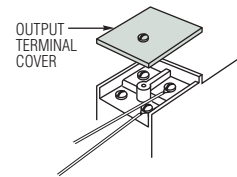

### Typical Wiring Diagram

Positive dual-channel Zener Barrier with floating leads.

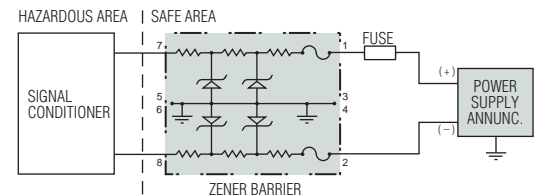

## How To Order

Specify Part Number based on the specifications tabulated below.

| DC Input to Barrier, Max.         | Signal Polarity | Total Series Resistance Per Channel | Application Group | Reactive Limits     |               | Part Numbers   |
|-----------------------------------|-----------------|-------------------------------------|-------------------|---------------------|---------------|----------------|
|                                   |                 |                                     |                   | Capacitance $\mu$ f | Inductance mh |                |
| 15 VDC, 200 mA                    | Positive        | 65                                  | D                 | 5.6                 | 0.7           | <b>54801</b> ⚡ |
| 20 VDC, 100 mA                    | Positive        | 270                                 | A, B              | 0.4                 | 0.9           | <b>54803</b> ⚡ |
|                                   |                 |                                     | C                 | 1.2                 | 5.0           |                |
|                                   |                 |                                     | D                 | 3.2                 | 10.0          |                |
| 20 VDC, 100 mA<br>(Full Ref. Sw.) | Positive        | 270                                 | A, B              | 0.4                 | 0.9           | <b>54805</b> ⚡ |
|                                   |                 |                                     | C                 | 1.2                 | 5.0           |                |
|                                   |                 |                                     | D                 | 3.2                 | 10.0          |                |
| 30 VDC, 60 mA                     | Positive        | 275                                 | D                 | 2.4                 | 6.0           | <b>54806</b> ⚡ |
| Optional Rail Mounting Clip       |                 |                                     |                   |                     |               | <b>61783</b>   |

### Notes:

- These barriers are internally fused. If a "fault" or abnormal signal level continues for a sustained period of time, the internal fusing within the barrier will open, disconnecting the barrier. External fuses (Littlefuse Type 3AG or equal) are recommended to protect the Barrier from incorrect wiring at start-up, or from other equipment fault.
- Housing material is blue Lexan®.
- All models shown are for Class I and II, Division 1 and 2. Specific Application Groups are tabulated.
- Ambient operating temperature for all models shown is -40°F to +140°F (-40°C to +60°C).
- Terminals 3, 4, 5 and 6 are common and are bonded to the mounting tabs for positive redundant grounding.

⚡ – Stock Items.

Installation and maintenance must be in accordance with the National Electrical Code and the applicable GEMS INSTRUCTION, INSTALLATION and SERVICE Bulletin available at [www.gemssensors.com](http://www.gemssensors.com)

## Typical Application Examples

Sensor switch may be any non-voltage-producing device. Typical are: flow and level switches, temperature switches (thermostats), pressure switches or passive, resistive transducers or transmitters. Below are typical examples.

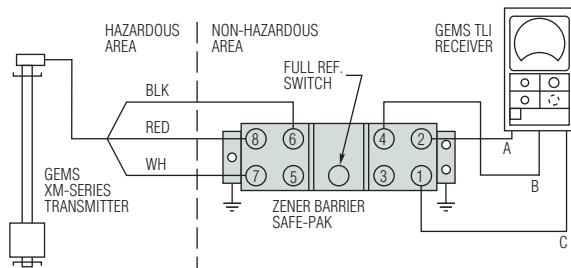

P/N 54805 in a continuous liquid level monitoring system.

Note: Terminals 3, 4, 5 and 6 are common and are bonded to the mounting tabs for positive redundant grounding.

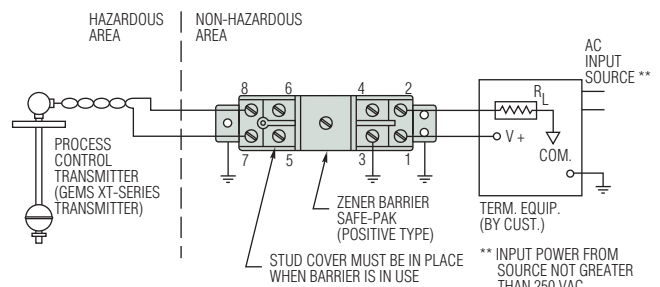

P/N 54806 in process control system.

### To Determine Loop Resistance:

$$R_{Loop} = \frac{V_A^* - 10}{.02}; R_{Loop} = R_{SUPPLY\ BARRIER} + R_{RETURN\ BARRIER} + R_{MONITORING\ EQUIPMENT}$$

\* $V_A$  must be less than 28 VDC (30 Volt Barriers)

# Non-Intrinsically Safe Relays

## Boost Your Sensor's Load Handling Ability

- ▶ SPST, N.O. Operation
- ▶ AC or DC models
- ▶ Amplify current handling capability of sensors for controlling high power loads
- ▶ Compact, polysulfone bodies are totally encapsulated
- ▶ Impervious to shock or vibration
- ▶ Solid-state reliability

GEMS solid-state switching units perform the functions of electro-mechanical relays, with the added reliability and advantages inherent in solid-state. Compact, totally encapsulated, and impervious to shock or vibration, these units mount anywhere... even directly on working machinery.

**LOAD-PAKS:** integrated, solid-state switches that amplify current handling capabilities of sensors for controlling high power loads. SPST, N.O. operation, AC and DC models.

**SPDT-PAKS:** enable one low-current sensor to control two independent loads up to 5 amps each. Switching is N.O. for one load and N.C. for the other.

**FLIP-PAKS:** provide low-current, "Start-stop" or "on-off" switching for industrial motor, liquid level and other control systems. Units hold operational state up to 1/2 second during momentary power loss to cut nuisance shutdowns; low voltage protection is inherent. 120 VAC and 240 VAC models handle loads to 5 amps.

### Dimensions

| LOAD-PAK, 5 Amp. A.C. | LOAD-PAK, 10 Amp, A.C.<br>LOAD-PAK, 2 Amp, D.C.<br>SPDT-PAK, FLIP-PAK |
|-----------------------|-----------------------------------------------------------------------|
|                       |                                                                       |

### Electrical Information

**DC LOAD-PAK:** Switching is by means of B+ closure. . .the DC LOAD-PAK must be wired to the polarity shown. REVERSING POLARITY WILL DESTROY THIS UNIT.

**SPDT-PAK:** This unit is designed to operate with a load connected to each of the two outputs. These loads must be 10 watts, minimum, for correct SPDT switching. One load used alone must be connected to the N.O. terminal. With this load, which may be less than 10 watts, the unit will operate the same as an SPST unit.

**Line Transients:** While random line transients will not normally harm LOAD-PAKS, they may pass current to some loads for up to 1/2 cycle duration\*. AC LOAD-PAKS and the DC LOAD-PAK include transient protection. . .the SPDT-PAK does not. If load transients are a problem, the external protective circuit, a properly-sized metal oxide varistor, may be used.

\* Mechanical holding or latching contacts (contactors) may cause some loads to latch under transient conditions.

LOAD-PAK®,  
5 AMP, AC



LOAD-PAK®,  
10 AMP, AC



### Intrinsically Safe

LOAD-PAK®,  
2 AMP, DC

Certified intrinsically safe under MSHA Certification No. 1951 for use on permissible equipment, for Group D use only.



FLIP-PAK



SPDT-PAK



**Surge Current Ratings of LOAD-PAKS.**

Non-repetitive.

| LOAD-PAK Rating | Overload Time  |          |         |
|-----------------|----------------|----------|---------|
|                 | .010 Sec.      | 1.0 Sec. | 10 Sec. |
|                 | Overload, Amps |          |         |
| 5 Amps, AC      | 30             | 20       | 10      |
| 10 Amps, AC     | 50             | 30       | 15      |

\*Mechanical holding or latching contacts (contactors) may be cause some loads to latch under transient conditions.

**Switch or Sensor Wiring:** Wires connecting external sensor switches to LOAD-PAKS should not be placed in raceways or conduits containing high voltage lines. Voltages induced from these lines trigger the low-power, solid-state triac, causing it to turn “on” momentarily.

**How To Order**

Specify Part Number based on the specifications tabulated below.

|                                                                   | LOAD-PAK<br>5 AMP, AC            | LOAD-PAK<br>10 AMP, AC | LOAD-PAK<br>2 AMP, DC         | SPDT-PAK<br>5 AMP, AC            | FLIP-PAK<br>5 AMP, AC         |
|-------------------------------------------------------------------|----------------------------------|------------------------|-------------------------------|----------------------------------|-------------------------------|
| <b>Part Number</b>                                                | 20173 ⚡                          | 26392 ⚡                | 25763 ⚡                       | 22155 ⚡                          | 28196 ⚡ 28244 ⚡               |
| <b>Operating &amp; Load Voltage Range</b>                         | 24 to 260 VAC                    |                        | 6 to 48 VDC                   | 100 to 130 VAC                   | 100 to 130 VAC 200 to 250 VAC |
| <b>Voltage Loss</b>                                               | 2 VAC                            |                        | 2 VDC                         | 3 VAC                            | 2 VAC                         |
| <b>Sensor Current, Max.</b>                                       | 20 mA                            |                        | 35 mA                         | 20 mA                            | 20 mA                         |
| <b>Allowable Resistance in Sensor Circuit to Turn “ON” (Max.)</b> | 4 k at Nom. Volt.                |                        | 0 to 4 k                      | 4 k at Nom. Volt.                | —                             |
| <b>Leakage Current Thru Load Term.</b>                            | 12 mA @ 240 VAC                  |                        | 2 mA                          | 20 mA                            | 12 mA @ 240 VAC               |
| <b>Switching Mode</b>                                             | SPST, N.O.                       |                        |                               | SPST, N.O. & N.C.                | SPST, N.O.                    |
| <b>Operating Temperature</b>                                      | 0°F to 120°F (-17.8°C to 48.9°C) |                        | 32°F to 120°F (0°C to 48.9°C) | 0°F to 120°F (-17.8°C to 48.9°C) |                               |

Note: All AC voltage and current specifications are RMS values unless otherwise stated.

⚡ – Stock Items

**Typical Wiring**

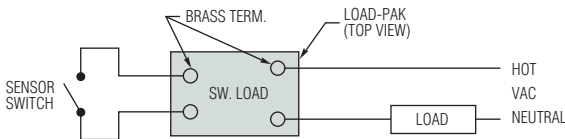

**LOAD-PAK**, Part Numbers 20173 and 26392 actuated by dry contact sensor to control load up to 10 amps, AC.

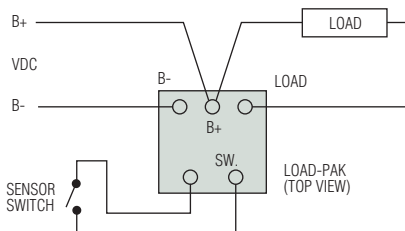

**LOAD-PAK**, Part Number 25763, actuated by dry contact sensor to control load up to 2 amps, DC.

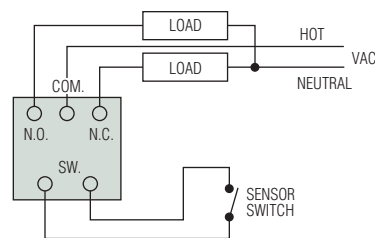

**SPDT-PAK**, actuated by a single sensor to control two separate loads.

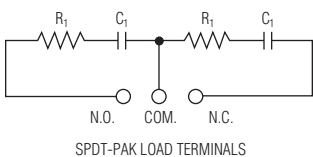

R = 100 OHM,  
1/4 WATT  
RESISTOR  
C = .05 MICROFARAD,  
500 V, CAPACITOR

**TRANSIENT PROTECTION FOR THE SPDT-PAK**, The circuit shown or a properly-sized metal oxide varistor may be used.

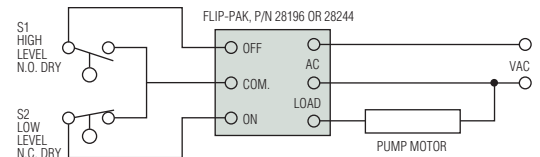

**FLIP-PAK**, providing pump up/down control.

**Refill:** Low level permits S2 to close, starting refill pump. Rising level allows S2 to open, and eventually closes S1 to actuate the FLIP-PAK “OFF” circuit and stop the pump motor. The FLIP-PAK “OFF” override assures pump shut-down even if S2 failed to open.

**Pump-Down:** With “ON” and “OFF” connections of S1 and S2 transposed at the FLIP-PAK, the pump is started by S1 and stopped by S2 at low level. The same “OFF” override prevails.

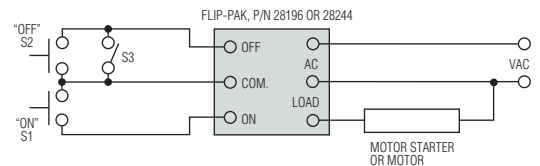

With two normally open, momentary contact push buttons (S1 and S2), the **FLIP-PAK** provides solid-state control of the motor starter or the motor itself... if load requirements are within FLIP-PAK ratings. S3 provides a safety shut-down. With S3 closed, the “ON” push button (S1) is rendered ineffective by the “OFF” override feature of the FLIP-PAK.